

Installation Instructions

Sartorius Weigh Cells

Models WZA225-CW, WZA26-CW

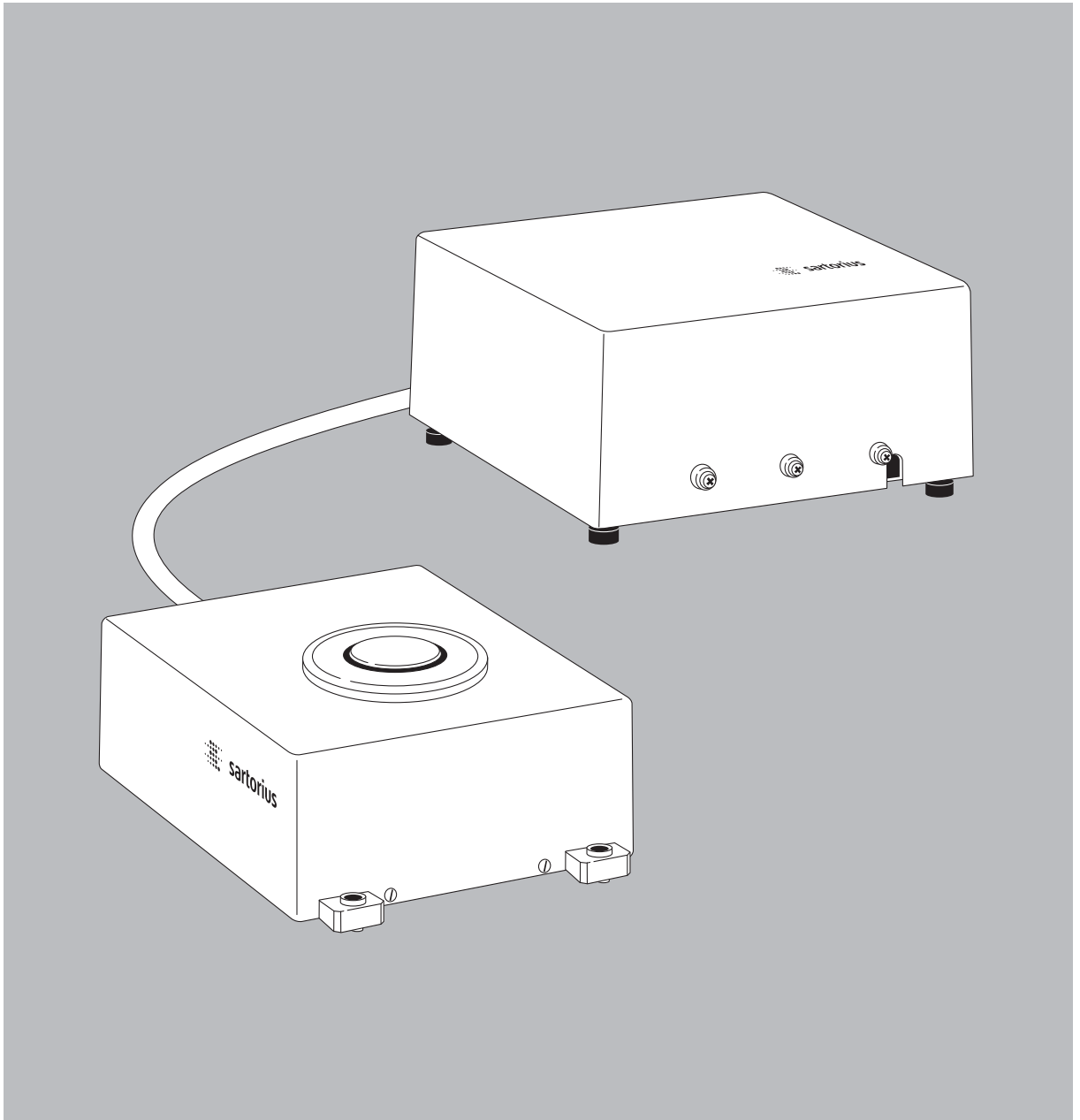

- 2 **Warnings and Safety Precautions**
- 3 **General View of the Equipment**
- 4 **Installation**
 - 4 Storage and Shipping Conditions
 - 4 Incoming Inspection
 - 4 Equipment Supplied
 - 4 Installation Instructions
 - 4 Connecting the Weigh Cell to the Electronics Module
 - 5 Connecting the Weigh Cell to AC Power
 - 6 Setting up the Weigh Cell
 - 6 Attaching a User-specific Transducer
 - 7 Leveling the Weigh Cell
- Operation**
 - 8 Notes on Analytical Weighing
 - 9 Below-Cell Weighing
- 10 **Configuration**
 - 11 Parameter Settings (Overview)
- 13 **Interface Port: RS-232**
 - 16 Pin Assignment Chart
 - 17 Cabling Diagram
- 18 **Troubleshooting Guide**
 - 19 **Overview**
 - 19 Specifications
 - 20 Dimensions (Scale Drawings)
 - 22 Accessories (Options)
 - 23 Declaration of Conformity

Description of the System

- The WZA225-CW/WZA26-CW is a compact weigh cell that can be affixed to a smooth surface.
- The weigh cell has a built-in calibration weight and can be calibrated and adjusted by transmitting a control command, or at the press of a key using the optional display and control unit.
- These compact weigh cells can be used to determine weights within restricted space.

The weigh cells have been developed for:

- Installation in measuring devices and production machinery
- High-precision weighing within limited space
- Precise weight determination on active production lines

Safety Precautions

- Once it has been installed, the weigh cell must be checked for the following:
 - Compliance with directives and standards for electrical apparatus
 - Electromagnetic compatibility of the complete weighing instrument
 - Compliance with mandatory safety regulations
- To prevent damage to the equipment, read these installation instructions carefully before operating the weigh cell.
- These installation instructions describe only the technological specifications of the weigh cell and the conditions that must be observed during installation. The specific procedures to follow when performing installation will depend on the particular system in which the weigh cell is installed.

⚠ Always make sure the equipment is disconnected from power before performing any installation, maintenance or repair work.

⚠ Exposure to excessive electromagnetic interference can cause the readout value to change. Once the disturbance has ceased, the instrument can be used again in accordance with its intended purpose.

⚠ The equipment may be opened only by authorized service technicians who have been trained by Sartorius and who follow Sartorius' standard operating procedures for maintenance and repair work.

⚠ Make absolutely sure to disconnect the electronics module from power before you connect or disconnect any electronic peripheral devices to or from the data interfaces.

Installation Requirements

⚠ Do not use this equipment in hazardous areas, zones exposed to explosive gases or dusts, nor areas exposed to potentially explosive materials.

⚠ Use of the weigh cell in areas where medical equipment is operated is not permitted.

⚠ If you connect a different weigh cell or electronics module from Sartorius, make sure to connect devices that are made to be operated together. Check the equipment numbers before connecting the devices.

⚠ Any incoming inspection or installation work that does not conform to the instructions in this manual will result in forfeiture of all claims under the manufacturer's warranty.

⚠ If you use electrical equipment in installations and under ambient conditions subject to stricter safety standards than those described in the manual, make sure you comply with the provisions as specified in the applicable regulations for installation in your country.

⚠ All components in the system must be grounded (earthed), including any draft shield added to the equipment. Connect an equipotential bonding conductor.

⚠ If you use electrical equipment in installations and under ambient conditions subject to stricter safety standards than those described in the manual, make sure you comply with the provisions as specified in the applicable regulations for installation in your country.

- Warning when using pre-wired RS-232 connecting cables: RS-232 cables purchased from other manufacturers often have incorrect pin assignments for use with Sartorius equipment. Be sure to check the pin assignments against the chart in these instructions before connecting the cable, and disconnect any lines identified differently from those specified by Sartorius.

- Note on installation: The operator shall be responsible for any modifications to Sartorius equipment and for connections of cables not supplied by Sartorius and must check and, if necessary, correct these modifications. On request, Sartorius will provide information on the minimum operating specifications (in accordance with the standards for defined immunity to interference).

○ If there is visible damage to the equipment or power cord, disconnect the equipment from power and replace the weigh cell and electronics module.

- Do not expose the equipment to aggressive chemical vapors or to extreme temperatures, moisture, shocks, or vibration.

○ If you have any problems with the equipment, contact your local Sartorius office, dealer or service center.

Hotline

- For technical support regarding the design, specifications or installation of the weigh cells, contact your local Sartorius dealer or contact the Sartorius hotline (in Germany) at:
Phone: +49.(0)551.308.4440
Fax: +49.(0)551.308.4449

General View of the Equipment

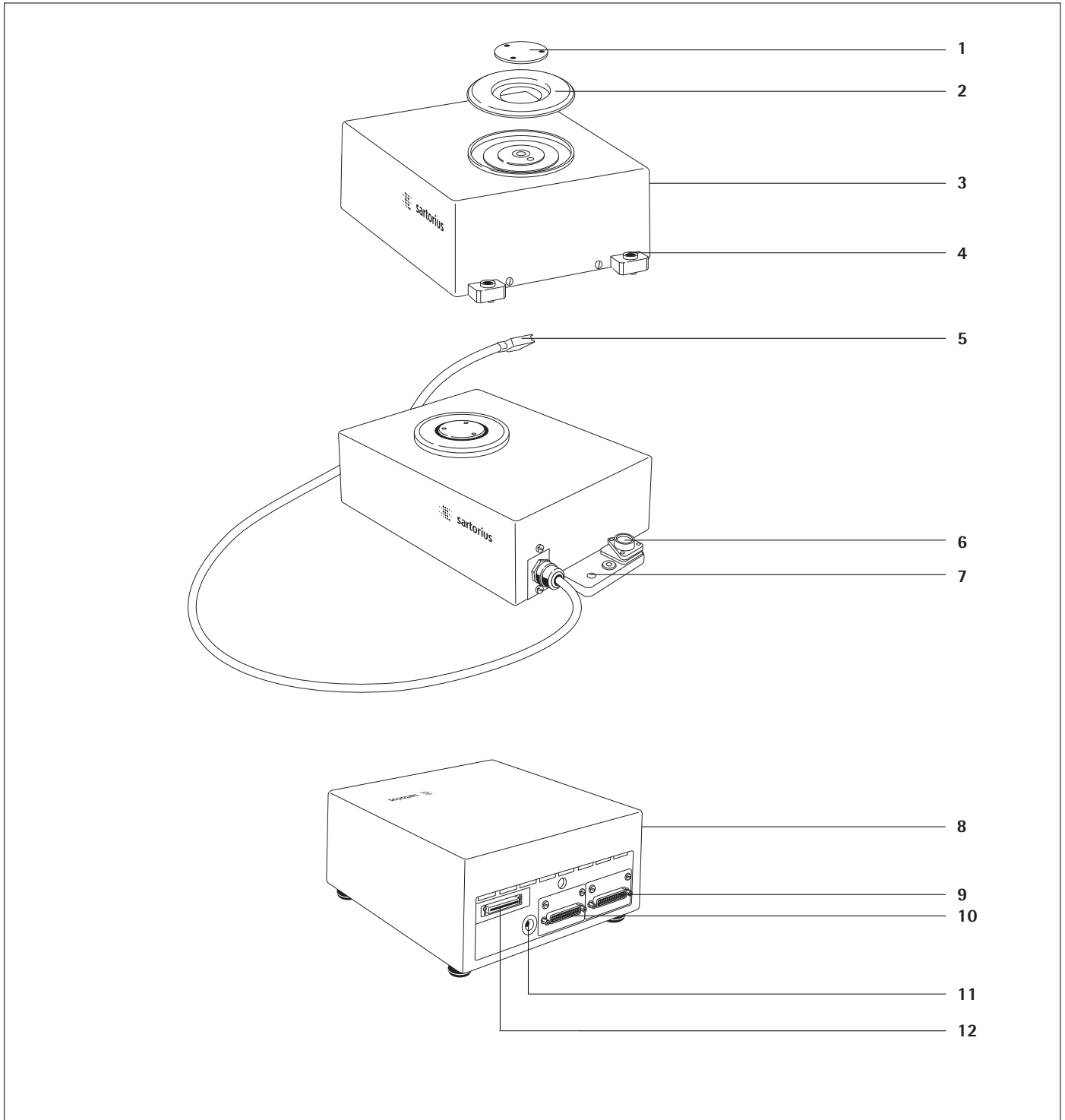

Pos.	Designation	Pos.	Designation
1	Load receptor	7	Bore hole for an equipotential bonding terminal
2	Shield ring	8	Electronics module
3	Weigh cell	9	COM -interface for peripheral device
4	Threaded bore hole (M6) for mounting the weigh cell	10	Printer interface*
5	Connector (male) for electronics module	11	DC jack
6	Level indicator	12	Socket for connecting the weigh cell
		*	= Functional only when the FF03-VF3659 indicator (optional) is connected

Installation

The weigh cells are available in various versions. If you have ordered special options, the weigh cells are equipped with the requested features at the factory.

Storage and Shipping Conditions

- Once the equipment has been removed from the packaging, it may lose accuracy if subjected to strong vibration. Excessively strong vibration may compromise the safety of the equipment.
- Do not expose the equipment unnecessarily to aggressive chemical vapors or to extreme temperatures, moisture, shocks, or vibration.
- It is a good idea to save the box and all parts of the packaging until you have successfully installed your equipment. Only the original packaging provides the best protection for shipment.
- Before packing your equipment for shipment, unplug all connected cables to prevent damage.
- △ If the equipment is to be shipped or otherwise transported over long distances, it must be packed in the original packaging; otherwise, Sartorius is not liable for any damage to the equipment.
- Do not expose the equipment to gravitational acceleration in excess of $\approx 300 \text{ m/s}^2$ (unless additional equipment is installed on the load receptor that enables it to withstand this force).

Incoming Inspection

The customer shall inspect the product and packaging immediately upon delivery for proper functioning, completeness, and absence of defects. This is to be performed in an incoming inspection within 10 days of delivery of the product. The incoming inspection must take place before the equipment is installed. Any obvious defects, errors, or incorrect delivery must be reported in writing. Defects detected at a later date must be reported in writing immediately upon detection.

Important note on incoming inspection:

- We recommend performing a repeatability test using an auxiliary draft shield to make sure the weigh cells were not damaged in transport. You can use the YAD011S software or the optional FF03-VF3659 display and control unit as an aid for this test.

Equipment Supplied

- Weigh cell
- Electronics module
- Installation instructions (this document)
- Special accessories as listed on the bill of delivery, if ordered, or in accordance with specific arrangements

Installation Instructions

The equipment is designed to provide reliable results under normal ambient conditions. If you have any questions or difficulties when developing your weighing system, please contact the specialists at Sartorius. When designing and setting up your weighing system, please observe the following so that you will be able to work with added speed and accuracy:

- Avoid exposing the equipment to the effects of extremely high temperatures; for example, caused by other electronic components, heaters or direct sunlight.
- Protect the equipment from drafts that come from open windows or doors.
- Maintain a constant ambient temperature when operating the equipment.

- Avoid exposing the equipment to excessive vibrations during weighing; for example, caused by motors or valves.
- Protect the equipment from aggressive chemical vapors.
- Do not expose the equipment to extreme moisture over long periods.

△ Always calibrate the weigh cell after transport.

- Equipment installed on the load receptor can interfere with weigh cell functions. The operator of the equipment accepts all liability for production release and the overall specifications of the equipment as connected within the particular system. The overall specifications attained by your system may differ from the specifications listed for the weigh cell in these instructions.

Conditioning the equipment:

Moisture in the air can condense on the surface of a cold weighing instrument or other device whenever it is moved to a substantially warmer place. If you transfer the equipment to a warmer area, make sure to condition it for about 2 hours at room temperature in the new location, leaving it unplugged from AC power.

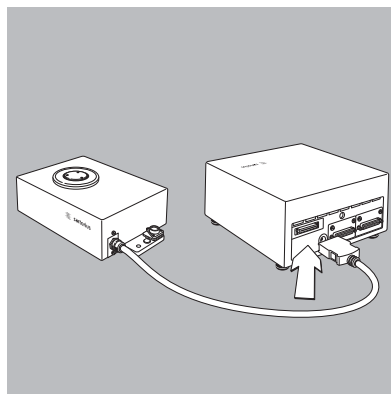

Connecting the Weigh Cell to the Electronics Module

- Plug the male connector on the cable into the female connector on the electronics module. Make sure the devices have identical serial numbers to avoid connecting components incorrectly.

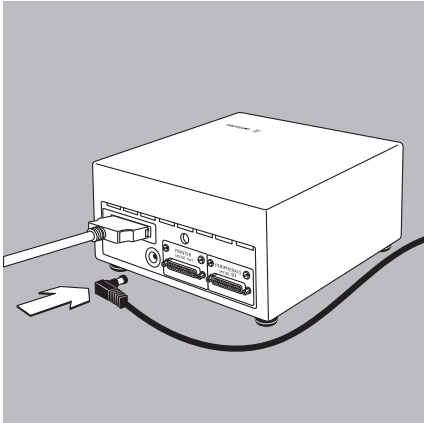

Connecting the Weigh Cell to AC Power

- Check the voltage rating and the plug design.
 - If they do not match your local rating or standard, contact your supplier.
 - Use only
 - Genuine Sartorius AC adapters or power supplies
 - AC adapters or power supplies approved by an authorized technician
- Insert the right-angle plug from the AC adapter into the jack on the electronics module.
- Connect the equipment to power:
 - plug the AC adapter into the wall outlet (mains)
- Power is supplied over the DC jack.
 - If the voltage specified on the label or the plug design of the AC adapter do not match your local rating or standard, please contact your Sartorius office or dealer.
- Using an AC adapter other than that supplied with the equipment:
 - The device can be operated with a supply voltage of 12 V to max. 26 V.
- ⚠ The power connection must be made in accordance with the regulations applicable in your country.

Safety requirements for operation of the evaluation electronics connected to a safety extra-low voltage (SELV) source:

The external power supply must meet the requirements of EN 61010-1, Section 6: "Protection Against Shock Current." Please also refer to the specifications for classification of electrically operated equipment in EN 61010-1, Appendix H.

Safety Precautions

The power supply must be rated to safety extra low voltage (SELV) or grounded (earthed) safety extra low voltage (SELV-E).

An AC adapter rated to Class 2 can be plugged into any wall outlet without taking additional safety precautions. The ground terminal is connected to the weigh cell housing. The electronics module must be grounded for operation. The data interface is also electrically connected (grounded) to the weigh cell housing.

EMC requirements:

The connector is designed for DC connections between equipment/systems that are not connected to a DC power supply. The cable length must not exceed 3 m.

To use an external power supply, the power source must meet the requirements of EN 61326. The following standards apply: Fast transients IEC 61000-4-4, Surge voltage IEC61000-4-5, Conductive HF signals IEC 61000-4-6

Connecting Electronic Peripheral Devices

- Make absolutely sure to unplug the weigh cell from AC power before you connect or disconnect a peripheral device (display and control unit or PC) to or from the interface port.

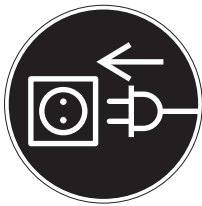

NOTE: This equipment has been tested and found to comply with the limits pursuant to part 15 of FCC Rules. These limits are designed to provide reasonable protection against harmful interference. This equipment generates, uses and can radiate radio frequency energy and, if not installed and used in accordance with these instructions, may cause harmful interference to radio communications.

For information on the specific limits and class of this equipment, please refer to the Declaration of Conformity. Depending on the particular class, you are either required or requested to correct the interference.

If you have a Class A digital device, you need to comply with the FCC statement as follows: "Operation of this equipment in a residential area is likely to cause harmful interference in which case the user will be required to correct the interference at his own expense."

If you have a Class B digital device, please read and follow the FCC information given below: "However, there is no guarantee that interference will not occur in a particular installation. If this equipment does cause harmful interference to radio or television reception, which can be determined by turning the equipment off and on, the user is encouraged to try to correct the interference by one or more of the following measures:

- Reorient or relocate the receiving antenna.
- Increase the separation between the equipment and receiver.
- Connect the equipment into an outlet on a circuit different from that to which the receiver is connected.
- Consult the dealer or an experienced radio/TV technician for help."

Before you operate this equipment, check which FCC class (Class A or Class B) it has according to the Declaration of Conformity included. Be sure to observe the information in this Declaration.

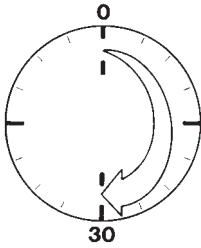

Warmup Time

The amount of warmup time required depends in part on the system in which the weigh cell is installed. To deliver exact results, the weigh cell must warm up for at least 4 hours after initial connection to AC power or after a relatively long power outage. Only after this time will the device have reached the required operating temperature.

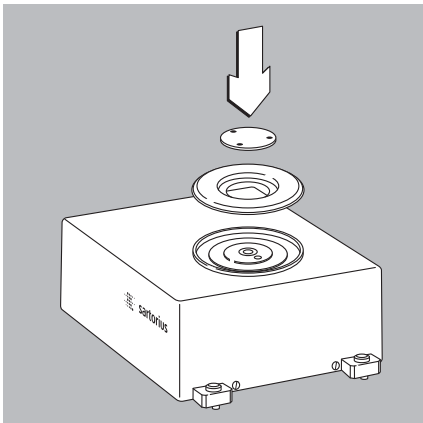

● Position the components listed below on the weigh cell in the order given:

- Shield ring
- Load receptor

Attaching a User-specific Transducer

- Attach any user-specific transducer to the threaded fastener on the load receptor and tighten it as indicated in the table of torque values below.
- ⚠ Make sure the user-specific transducer is rigid, and is firmly attached to the load receptor.

Maximum permissible load on load receptor:

Model	M_{corner}	M1	M2
WZA225-X	0.5 Nm	1 Nm	0.8 Nm*
WZA26-X	0.25 Nm	0.5 Nm	0.8 Nm*

*) No weighing pan installed

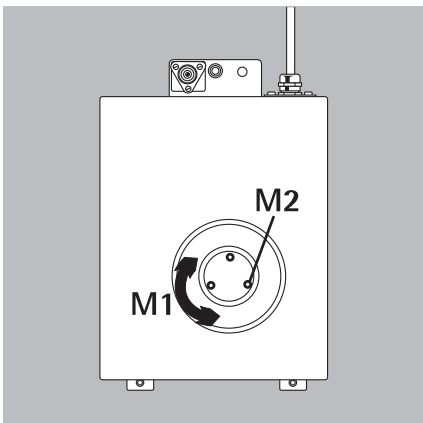

The off-center load moment listed under M_{corner} must not be exceeded by off-center loads, as this may result in damage to the weigh cell.

The force "G" is made up of the weight force exerted by the sample and the off-center load exerted on the load receptor.

The load receptor must be resistant to bending and twisting forces.

The overload protection of the weigh cell protects only against vertical overloading. The equipment operator must take steps to prevent other overloads that may occur during operation.

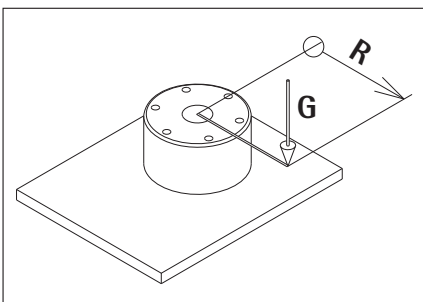

G = Load
 R = Distance from pan center
 $M_{\text{corner}} = G \cdot R$

Example: Maximum length of the cantilever in the WZA225-CW

A uniform cross-section of the cantilever is assumed. The weight of the cantilever is estimated at 50 g.

$$M_{\text{corner cantilever}} \approx \frac{1}{2} R \times G_{\text{cantilever}}$$

$$G_{\text{cantilever}} = 9.81 \text{ m/s}^2 \times 0.05 \text{ kg} = 0.49 \text{ N}$$

$$M_{\text{corner load}} = R \times G_{\text{load}}$$

$$G_{\text{load}} = 9.81 \text{ m/s}^2 \times 0.15 \text{ kg} = 1.47 \text{ N}$$

$$M_{\text{corner}} = M_{\text{corner cantilever}} + M_{\text{corner load}}$$

$$= R (\frac{1}{2} \times G_{\text{cantilever}} + G_{\text{load}})$$

$$R = \frac{M_{\text{corner}}}{(\frac{1}{2} G_{\text{cantilever}} + G_{\text{load}})}$$

$$R = 0.5 \text{ Nm} / 1.715 \text{ N}$$

$$R = 0.29 \text{ m}$$

In this example, the cantilever must not exceed 290 mm in length, otherwise damage to the system may result. Handling of the equipment during use may exert additional moment which, must be taken into account. Generally, we recommend testing the cantilever with the weigh cell before putting the equipment into operation, to avoid unwanted feedback effects in the control loop and to account for the effects of drafts.

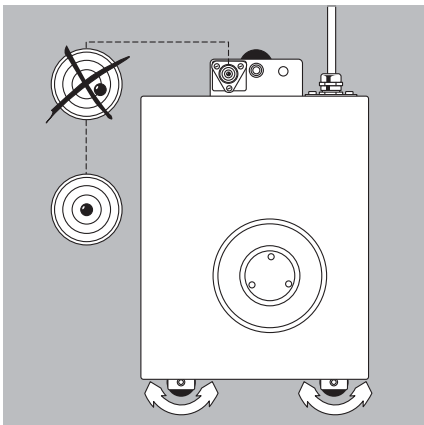

Leveling the Weigh Cell in a Portable Weighing System (Leveling Feet Optional)

Purpose:

- To compensate for uneven areas at the place of installation.
 - To ensure that the weigh cell is placed in a perfectly horizontal position for consistently reproducible weighing results.
- Always level the weigh cell again any time after it has been moved to a different location.

- Leveling feet are not included with the equipment supplied. The following leveling feet are available:
 - Standard leveling foot, order number 69B20005
 - Designer feet (set of four), order number 69MA0195
- Adjust the leveling feet until the air bubble is centered within the circle on the level indicator.

Permanently Installed Weigh Cells

- Adjust the weigh cell after it has been installed in the system in its permanent location (see next page). The weigh cell must be leveled again any time the location or position of the weighing system is changed.

- For optimum operation, install the weigh cell in a horizontal position.

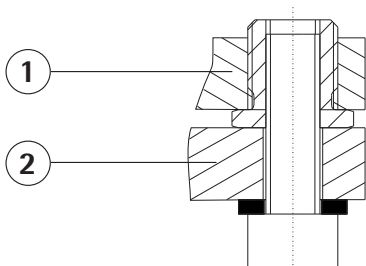

- 1) Bottom plate of the weigh cell
- 2) Fastening frame of the system

- Fastening with M6 screws: Connection to the threaded fasteners on the weigh cell (1) (torque: 2.5 Nm)

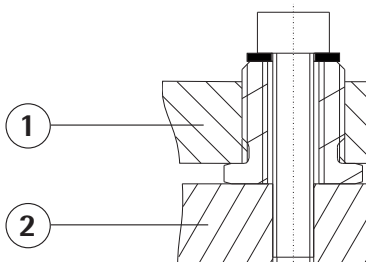

- Fastening with M4 screws: Connection to the threaded fasteners of a user-specific frame (2).

Operation

Notes on Analytical Weighing with Weigh Cells

Handling of Samples and Containers

Samples should be acclimatized to the temperature of the weigh cell to avoid negative effects on results, such as measurement errors and fluctuations caused by air buoyancy resulting from convection currents across the surface of the sample.

These negative effects increase as the volume and/or surface area of the sample increases. For this reason, the size of the container should be appropriate for the sample.

Samples and containers should not be touched by the operator's hands, as the hygroscopic effect of fingerprints and the effect of the hand's temperature can influence the measurement results.

Samples must be applied very carefully, whether manually (using a forceps) or automatically (by a robot or filling system).

When designing a draft shield device, steps must be taken to keep the resulting increase in temperature within the weighing chamber to a minimum (e.g., using a bypass).

Weighing Electrostatically Charged Samples or Containers

If a sample or container is electrostatically charged, significant errors may result during weighing. Materials with low conductivity, such as glass, plastic or filters, are particularly susceptible to static electricity (resulting e.g. from friction) because the weighing pan can discharge the static electricity only very slowly.

The result is a force action between the charge on the sample and the permanently installed parts of the weigh cell. This causes the readout to fluctuate constantly.

Ionization can be applied, to make the air around the sample conductive. This allows the charge to be compensated through the air, or discharged through the ground (grounded).

Aside from purely mechanical solutions (e.g., using a special weighing pan to shield the system), bombarding the sample with ions of opposing polarity to neutralize the surface charge is one of the most effective methods for eliminating static electricity. Sartorius can provide ionization devices for installation in weighing systems.

The area around the weigh cell can also contain charges that negatively affect the accuracy of weighing results. Appropriate steps taken in the design of a draft shield device can counteract such effects.

Weighing Magnetic or Magnetizable Samples

For technical reasons, the use of magnetizable materials in the manufacture of weigh cells is unavoidable, primarily because the operating principle of high-resolution weigh cells is based on compensation of the load through magnetic forces.

When weighing magnetic or magnetizable samples or containers, interaction between the sample or container and certain parts inside the weigh cell may have a distorting effect on the weighing results.

To keep such effects to a minimum, we recommend increasing the distance between the sample/container and the weighing system using a non-magnetic material. The force is reduced quadratically with the increase in distance.

Magnetizable or magnetized samples and the weigh cell itself interact with magnetic fields and magnetizable or magnetized parts in the area surrounding the weighing system. The system can be shielded from external magnetic fields to some extent using (soft magnetic) plates.

Calibration/Adjustment

Calibration/adjustment can be performed as follows:

- Using control commands sent by the YAD011S configuration software from Sartorius, installed on a computer (see page 14 for the commands),
or
- Using an optional display and control unit

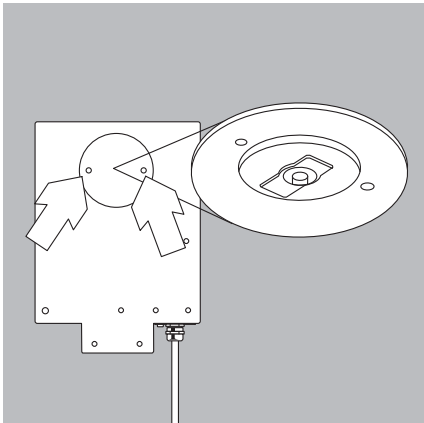

Below-Cell Weighing

A port for a below-cell weighing hanger is located on the bottom of the weigh cell.

- Remove the cover plate: remove the screws and then remove the plate.
- Threaded fastener for hook: M3
- ⚠ There is no overload stop.
- Install the special hook (not included in delivery) carefully; max. torque: 0.5 Nm
- If desired, install a shield for protection against drafts.

Configuration

Purpose

The weigh cell is configured at the factory. The factory settings can be adapted to individual requirements by editing the operating menu ("Setup").

Features

The parameters are divided into the following groups (highest menu level):

- 1 Weigh cell functions ("Weighing")
- 5 Interface
- 6 & 7 Print in weighing mode
- 8 Extra functions
- 9 Restore factory settings

Factory Settings for Menu Parameters

The factory-set configurations are identified by an "o" in the list below.

Customer-specific settings can be configured on request.

Preparation

- Using the YAD01IS configuration software from Sartorius, you can process the operating menu parameters as follows:

- read
- edit
- print
- save

- Operation with the optional display and control unit:

- The menu is extended by the addition of application programs.
- The display and control unit has a separate processor for configuring the settings.

- △ Not all of the settings remain effective when the display and control unit has been disconnected.

For more detailed information on configuration of the weigh cell, please contact Sartorius.

Parameter Settings (Overview)

- o Factory setting
- ✓ User-defined setting

Operating menu	1 Weighing	1 1	Adapt filter	1 1 1	Very stable conditions
				1 1 2	o Stable conditions
				1 1 3	Unstable conditions
				1 1 4	Very unstable conditions
		1 2	Application filter	1 2 1	o Final readout
				1 2 2	Filling (manual)
				1 2 3	Low filtering (computer-aided filling)
				1 2 4	W/o filtering (checkweigher operation)
		1 3	Stability range The stability symbol remains displayed when the value is stable within this range	1 3 1	1/2 digit
				1 3 2	1/4 digit
				1 3 3	1 digit
				1 3 4	o 2 digits
				1 3 5	4 digits
				1 3 6	8 digits
		1 4	Stability delay	1 4 1	No delay
				1 4 2	o Short delay
				1 4 3	Long delay
				1 4 4	Extremely long delay
		1 5	Tare function	1 5 1	Without stability
				1 5 2	o After stability
1 6	Auto zero	1 6 1	o On		
		1 6 2	Off		
	1 7	through 1 15	see next page		

Operating menu	1 Weighing	1 1 through 1 6	see previous page		
		1 7	Weight unit 1	1 7 2	Grams (display: g)
				1 7 4	Carats
				1 7 5	Pounds
				1 7 6	Ounces
				1 7 7	Troy ounces
				1 7 8	Hong Kong taels
				1 7 9	Singapore taels
				1 7 10	Taiwanese taels
				1 7 11	Grains
				1 7 12	Pennyweights
				1 7 13	o Milligrams
				1 7 14	Parts per pound
				1 7 15	Chinese taels
		1 7 16	Mommes		
		1 7 17	Austrian carats		
		1 7 18	Tola		
		1 7 19	Baht		
		1 7 20	Mesghal		
	1 8	Display/output accuracy	1 8 1	o All digits	
			1 8 2	Reduced for load change	
			1 8 3	Index +1	
			1 8 4	Index +2	
			1 8 5	Reduced by 1 digit	
	1 9	Calibration/adjustment, linearization and preload	1 9 1	External calibration/adjustment with factory-set weight value	
			1 9 2	External calibration/adjustment with weight detection	
			1 9 3	External calibration/adjustment with user-defined weights	
			1 9 4	o Internal calibration/adjustment	
			1 9 6	External linearization with factory-set weight value	
			1 9 7	External linearization with user-def. weights	
			1 9 8	Store preload	
			1 9 9	Clear preload	
			1 9 10	Calibration/adjustment/linearization blocked	
	1 10	Calibration/adjustment sequence	1 10 1	o Calibrate, then auto adjust	
			1 10 2	Calibrate; manual adjust if desired*	
	1 11	Zero-setting range	1 11 1	1 %/max. cap.	
			1 11 2	o 2 %/max. cap. Extended zero-setting range available on request	
	1 12	Initial zero setting range	1 12 1	o 3 to 5 %/max. cap. (depending on model)	
			1 12 2	2 %/max. cap.	
			1 12 3	5 %/max. cap.	
			1 12 4	10 %/max. cap.	
	1 13	Tare/zero at power-on	1 13 1	o On	
			1 13 2	Off	
			1 13 3	Only zero at power on	
	1 14	Display update	1 14 1	o Normal output rate	
			1 14 2	Accelerated output rate	

* = Activate the calibration function again to adjust the weigh cell, or press CF to end the calibration routine without adjusting.

Operating menu	5 Interface	5 1 Baud rate	5 1 1	150 baud
			5 1 2	300 baud
			5 1 3	600 baud
			5 1 4	o 1,200 baud
			5 1 5	2,400 baud
			5 1 6	4,800 baud
			5 1 7	9,600 baud
			5 1 8	19,200 baud
		5 2 Parity	5 2 1	Mark
			5 2 2	Space
			5 2 3	o Odd
			5 2 4	Even
		5 3 Number of stop bits	5 3 1	o 1 stop bit
			5 3 2	2 stop bits
		5 4 Handshake mode	5 4 1	Software
	5 4 2		Hardware, 2 characters after CTS	
	5 4 3		o Hardware, 1 character after CTS	
	5 5 Communication mode	5 5 1	o SBI mode (ASCII)	
		5 5 2	XBPI mode (binary) ¹⁾	
	6 Print	6 1 Manual/auto print	6 1 1	Manual without stability
			6 1 2	o Manual after stability
			6 1 3	Manual at stability
			6 1 4	Automatic without stability
			6 1 5	Automatic at stability
		6 2 Stop automatic printing function	6 2 1	Manual with print command/key
6 2 2			o Not stoppable	
6 3 Time-dependent printing		6 3 1	o 1 display update	
		6 3 2	2 display updates	
		6 3 3	5 display updates	
		6 3 4	10 display updates	
		6 3 5	20 display updates	
		6 3 6	50 display updates	
		6 3 7	100 display updates	
7 Print		7 2 Line format of printout	7 2 1	o 16 characters
	7 2 2		22 characters ²⁾	
8 Extra functions	8 1 Menu	8 1 1	o Parameter settings alterable	
		8 1 2	Parameters "read only"	
	8 4 External switch function	8 4 1	o Print	
		8 4 2	Tare	
		8 4 3	Function key F1	
		8 4 4	"Toggle" function key	
	8 6 Power-on mode for weighing platform	8 6 1	Off/on/standby ²⁾	
		8 6 2	Off/on ₂)	
		8 6 3	On/standby ²⁾	
8 6 4		o Auto on		
9 Reset menu	9 1 Factory settings	9 1 1	Restore	
		9 1 2	o Do not restore	

¹⁾ XBPI extended operating mode = additional commands for communication between weigh cell and computer. For more information, please contact Sartorius.

²⁾ Function available only when operating the optional display and control unit or YAD011S software

Interface Port: RS-232

Purpose

The weigh cell has a communication interface for peripheral devices, such as a computer or other device.

A printer interface is also available. The printer interface functions only if the optional FF03-VF3659 display and control unit is connected.

Connecting a computer:

You can connect a computer to change, start and monitor the functions of the weigh cell.

Features

Type of interface:	Serial interface
Operating mode:	Full duplex
Standard:	RS-232
Transmission rates:	150, 300, 600, 1200, 2400, 4800, 9600 and 19,200 baud
Parity:	Space, odd, even
Character format:	Start bit, 7-bit ASCII, parity, 1 or 2 stop bits
Handshake mode:	For 2-wire interface: software (XON/XOFF) For 4-wire interface: hardware (CTS/DTR)
Operating mode:	SBI (ASCII), XBPI*

* XBPI operating mode:

9600 baud, 8 bits, odd parity, 1 stop bit.

There are a number of commands for use in communication between weigh cell and computer.

For more information, please contact Sartorius.

Factory settings for SBI operating mode:

Transmission rate:	1200 baud	(menu code 5 1 4)
Parity:	Odd	(menu code 5 2 3)
Stop bits:	1 stop bit	(menu code 5 3 1)
Handshake mode:	Hardware, 1 character after CTS	(menu code 5 4 3)
Operating mode:	SBI	(menu code 5 5 1)
Print manually/automatically	Manually after stability	(menu code 6 1 2)
Stop automatic printing:	Not possible	(menu code 6 2 2)
Time-dependent autoprint:	After 1 display update	(menu code 6 3 1)

Preparation

- See page 16 for the pin assignment chart and cabling diagram.

Data Output Format

Data is output with 16 characters per line.

Example:

+ 253 p c s

Data Output Format with 16 Characters

Display segments that are not activated are output as spaces. Values with no decimal point are output without a decimal point.

The type of character that can be output depends on the character's position:

Normal Operation

Position	1	2	3	4	5	6	7	8	9	10	11	12	13	14	15	16
	+	D	D	D	D	D	D	D	D	D	*	U	U	U	CR	LF
or	-	*	*	*		
or	*	*	*	*	*	*	*	*	*	*	*					

- *: Space
- D: Digit or letter
- U: Unit symbol
- CR: Carriage return
- LF: Line feed

Special Codes

Position	1	2	3	4	5	6	7	8	9	10	11	12	13	14	15	16
	*	*	*	*	*	*	-	-	*	*	*	*	*	*	CR	LF
or							H	H								
or							L	L								
or							C									

*:	Space
- -:	Final readout mode
H:	Overload
H H:	Overload in Checkweighing (Function available only when operating the optional display and control unit or the YAD011S software)
L:	Underload
L L:	Underload in Checkweighing
C:	Calibration/adjustment

Error code

Position	1	2	3	4	5	6	7	8	9	10	11	12	13	14	15	16
	*	*	*	E	r	r	*	#	#	#	*	*	*	*	CR	LF

*:	Space
# # #:	Error code number

Example: Output of the weight value +1255.7 g

Position	1	2	3	4	5	6	7	8	9	10	11	12	13	14	15	16
	+	*	*	*	1	2	5	5	.	7	*	g	*	*	CR	LF

Position 1:	Plus or minus sign or space
Position 2:	Space
Positions 3–10:	Weight with a decimal point; leading zeros = space
Position 11:	Space
Positions 12–14:	Unit symbol or space
Position 15:	Carriage return
Position 16:	Line feed

Data Input Format

The computer connected to the interface can be used to send commands controlling weigh cells functions.

These control commands may have different formats. Control commands consist of up to 26 characters. Each character must be transmitted according to the settings configured in the operating menu for data transmission.

Formats for Control Commands

Format 1:	Esc	!	CR	LF		
Format 2:	Esc	!	#	_	CR	LF

Esc:	Escape	!:	Command character
#:	Digit		
_:	Underline (ASCII 95)		
CR:	Carriage return (optional)		
LF:	Line feed (optional)		
Max:	depends on command character; i.e. parameter input beyond the maximum length is truncated, not discarded as in the case of keypad input		

Format 1 (example: ESC K)

!	Meaning
K	Adapt filter (ambient conditions): very stable conditions
L	Adapt filter: stable conditions
M	Adapt filter: unstable conditions
N	Adapt filter: very unstable conditions
O	Block all keys
Q	Acoustic signal (beep)
P	Print
R	Release (unblock) keys
S	Restart
T	Tare and zero
Z	Internal calibration/adjustment

Format 2 (example: ESC f3_)

!#	Meaning
f1_	Calibration/adjustment in accordance with menu code 1 9 xx
f3_	Zero
f4_	Tare without zeroing
s1_	External calibration/adjustment
s3_	Clear function [CF]
x0_	Internal calibration
x1_	Print weigh cell type
x2_	Print serial no. of weigh cell
x3_	Weigh cell software version

Synchronization

During data communication between the weigh cell and a connected computer, messages consisting of ASCII characters are transmitted via the interface. For error-free data communication, the parameters for baud rate, parity, handshake mode and character format must be the same for both units.

You can set these parameters in the operating menu so that they match those of the connected device. You can also define parameters in the weigh cell to make data output dependent on various conditions. The conditions that can be configured are listed in the descriptions of the application programs. If you do not connect a peripheral device to the interface port, this will not generate an error message.

Handshake

The weigh cell interface (SBI) has transmit and receive buffers. You can define the handshake parameter in the operating menu (menu code 5 4 x):

- Hardware handshake (CTS/DTR)
- Software handshake (XON, XOFF)

Hardware Handshake

With a 4-wire interface, 1 more character can be transmitted after CTS (clear-to-send).

Software Handshake

The software handshake is controlled via XON and XOFF. When a device is switched on, XON must be transmitted to enable any connected device to communicate. When the software handshake is configured in the operating menu, the hardware handshake becomes active after the software handshake.

The data transmission sequence is as follows:

Weigh cell (transmitting device)	--- byte ---> --- byte ---> --- byte ---> --- byte ---> <--- XOFF --- --- byte ---> --- byte ---> ... (Pause) ... <--- XON --- --- byte ---> --- byte ---> --- byte ---> --- byte --->	Computer (receiving device)
----------------------------------------	----------------------------------------------------------------------------------------------------------------------------------------------------------------------------------------------------------------------------------	-----------------------------------

Transmitting device:

Once XOFF has been received, it prevents further transmission of characters. When XON is received, it re-enables the transmitting device to send data.

Receiving device:

To prevent too many control commands from being received at one time, XON is not transmitted until the buffer is almost empty.

Activating Data Output

Data output can be activated by sending a print command or automatically, either synchronously with the display or at defined display update intervals (see application program descriptions and autoprnt setting).

Data Output by Print Command

The print command can be transmitted by sending a software command (Esc P).

Automatic Data Output

In the "auto print" operating mode, data is output to the interface port without a print command. You can have data output automatically at defined display update intervals, with or without the stability parameter. The length of a print interval depends on the weigh cell model and operating mode.

If you select the auto print setting, data is transmitted immediately as soon as you turn on the weigh cell. In the operating menu, you can define whether or not automatic printing can be stopped by pressing the "Print" key.

Faster Output Speeds

If you require measured value output at speeds faster than 10 Hz, please contact Sartorius for further information (see also menu item 1 14 2 in the chapter entitled "Configuration").

Pin Assignment Chart

Female interface connector:

25-contact D-Submini (DB25S) with screw lock hardware

Male connector used (please use connectors with the same specifications):

25-pin D-Submini (DB25S) with shielded cable clamp assembly (Amp type 826 985-1C) and fastening screws (Amp type 164 868-1)

Pin assignments:

Pin 1:	Signal ground	
Pin 2:	Data output (TxD)	
Pin 3:	Data input (RxD)	
Pin 4:	Signal return (TxD/RxD)	
Pin 5:	Clear to send (CTS)	
Pin 6:	Internally connected	
Pin 7:	Internal ground	
Pin 8:	Internal ground	
Pin 9:	Reset_In*)	
Pin 10:	-12 V	
Pin 11:	+12 V	
Pin 12:	Reset_Out *)	
Pin 13:	+ 5 V	
Pin 14:	Internal ground	
Pin 15:		Universal switch function
Pin 16:		
Pin 17:		Control output 1: "lighter" ¹⁾
Pin 18:		Control output 2: "equal" ¹⁾
Pin 19:		Control output 3: "heavier" ¹⁾
Pin 20:	Data terminal ready (DTR)	Control output 4: "set" ¹⁾
Pin 21:	Supply voltage ground, COM	
Pin 22:	Not connected	
Pin 23:	Not connected	
Pin 24:	Supply voltage input +15 to 25 V	
Pin 25:	+5 V	

*) = Hardware restart

¹⁾ = Control output only in conjunction with the optional FF03-VF3659 display and control unit

Cabling Diagram

For connecting a computer or other peripheral device to the weigh cell using the RS-232C/V24 protocol and cable lengths of up to 15 m (approx. 50 ft).

Important: Do not connect any other pins in the weigh cell.

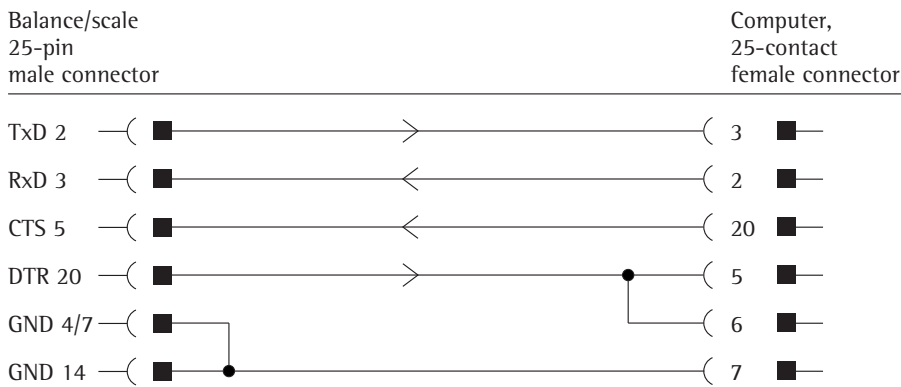
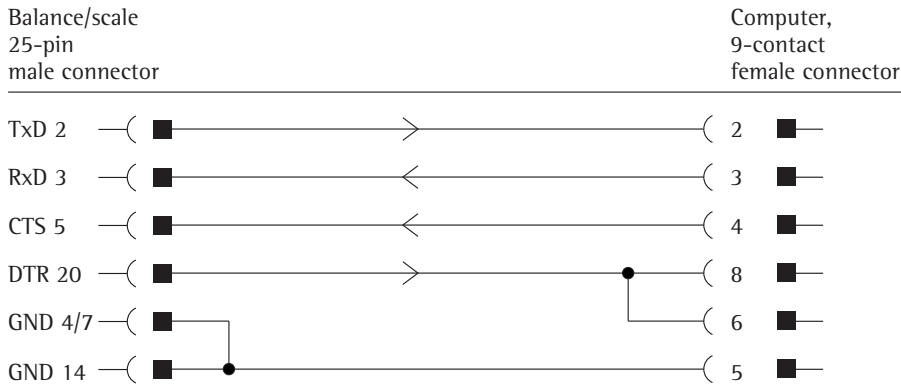

Cable type: AWG 24 specification

Troubleshooting Guide

Error codes are displayed for about 2 seconds. The program then returns automatically to the previous mode.

Display	Cause	Solution
No segments appear	No AC power is available Power supply not plugged in	Check the AC power supply Connect power supply to the wall outlet (mains)
H	The load exceeds the weigh cell capacity	Unload the weigh cell
L or Err 54	Load receptor is not in place	Place load receptor on weigh cell / Set preload
Err 01	Data output not compatible with output format	Change the configuration in the operating menu
Err 02	Calibration/adjustment condition not met, e.g., – not tared – load on load plate	Calibrate only when zero is displayed Tare the weigh cell Unload the weigh cell
Err 03	Calibration/adjustment could not be completed within the required time period Very unstable conditions	Allow the scale to warm up again and repeat the adjustment Adapt menu settings
Err 06	Built-in calibration weight defective	Contact the Sartorius Service Center
Err 07	Function not allowed	Contact your local Sartorius Service Center for assistance in changing configuration settings
Err 08*	The load on the weigh cell is too heavy to zero the readout	Check whether the “Initial zero-setting range” is configured
Err 09*	No tare possible when gross \leq zero	Zero the weigh cell
Err 10	Tare key blocked when there is data in tare memory (net-total). Only one tare function can be performed at a time	Delete the tare memory by pressing CF (clear function) to make the tare key accessible again
Err 11	Tare memory not allowed	Check the value entered
Err 12	Tare memory greater than weighing range or range limits	Check the sample or container
Err 17	Internal adjustment not possible because preload is too heavy	Reduce preload, change the configuration settings, or use the YAD011S software to set the preload
Err 30	Interface port for printer output blocked	Contact the Sartorius Service Center
Err 235	Connecting cable not plugged in correctly Cable connected to electronics module from a different weigh cell	Connect the cable correctly Connect the equipment Connect the components correctly
Err 340	Operating parameters (EEPROM) are defective	Contact the Sartorius Service Center
NO WP	Weighing platform defective Function blocked	Contact Sartorius the Service Center None
The weight readout changes constantly	Unstable ambient conditions (excessive vibration or draft) at the place of installation A foreign object is caught between the load plate and the housing	Set up the weigh cell in another area Remove the foreign object
The weight readout is obviously wrong	The weigh cell was not calibrated/adjusted The weigh cell was not tared The weigh cell is not level	Calibrate/adjust the weigh cell Tare before weighing Level the weigh cell

If any other errors occur, contact the Sartorius Service Center.

* Occurs only when operated over the SBI interface (ESC f3_)/f4_)

Overview

Specifications

Model	Standard specifications		Customer-specific modifications
	WZA225-CW	WZA26-CW	
Weighing capacity	g	220	20
Readability	mg	0.01	0.001
Maximum preload on pan support w/o limiting the weighing range; average ²⁾	g	0	12.5 g necessary
Maximum preload on pan support when using the built-in motorized calibration weight, average ²⁾	g	110	12.5 g
Tare range (subtractive)	g	100% of the maximum capacity	
Repeatability (standard deviation) ¹⁾	≤±mg	0.03	0.003
Linearity	≤±mg	0.15	0.02
Response time ¹⁾	s	< 6	< 6
Adaptation to ambient conditions		By selection of 1 of 4 optimized filter levels	
Display update (depends on filter level selected)	s	0.1 to 0.4	
Operating temperature range	°C	10° to 30° (50° to 86°F)	
Allowable ambient operating temperature	°C	5° to 40° (41° to 104°F)	
Sensitivity drift within +10 to +30 °C	≤±/K	1 · 10 ⁻⁶	
External calibration weight (of at least accuracy class...)	g	50 (E2)	5 (E2)
Material:		Nickel-plated aluminum (load receptor: chemically nickel-plated aluminum)	
– Weigh cell		Painted aluminum	
– Electronics module:			
Net weight, approx.	kg	7.2	
AC power source/ power supply	V~	Portable AC adapter, 230 V or 115 V +15% to -20% (IP20 protection), power consumption: up to 35 VA	
Frequency	Hz	48–60	
Alternatively:			
Supply voltage	VDC	max. 12–25	
from customer's system	VDC	typically 14.5	
Ripple 50/60 Hz		0.5 Vpp (Voltage peak-to-peak)	
Power consumption		Average: 4 W (weigh cell only)	
Power consumption: switch-on current		Average: 6 W (weigh cell only); with optional display and control unit: 7 W (weigh cell + display and control unit)	
Built-in interface		RS-232C-S/V24-V28; 7-bit; parity: even, odd, mark, or space; transmission rates: 150 to 19,200 baud; 1 or 2 stop bits; software/hardware handshake	

¹⁾ = depends on system design

²⁾ = for operation with greater preload setting, please send e-mail to request YAD011S configuration software;
e-mail address: fast.factory@sartorius.com

Overview

Dimensions (Scale Drawings)

Electronics module:

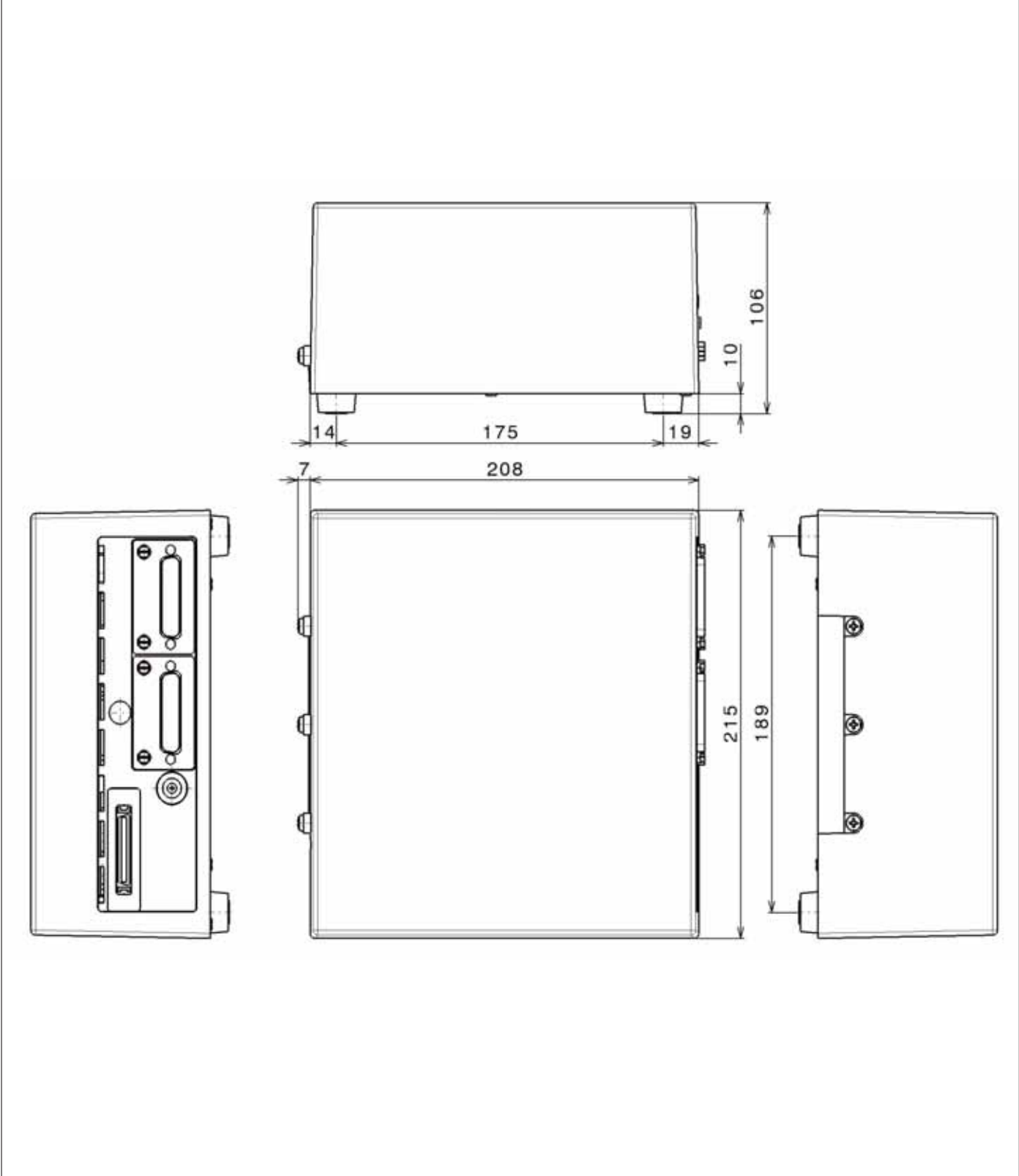

All dimensions are given in millimeters

Weigh cell models WZA225-CW, WZA26-CW:

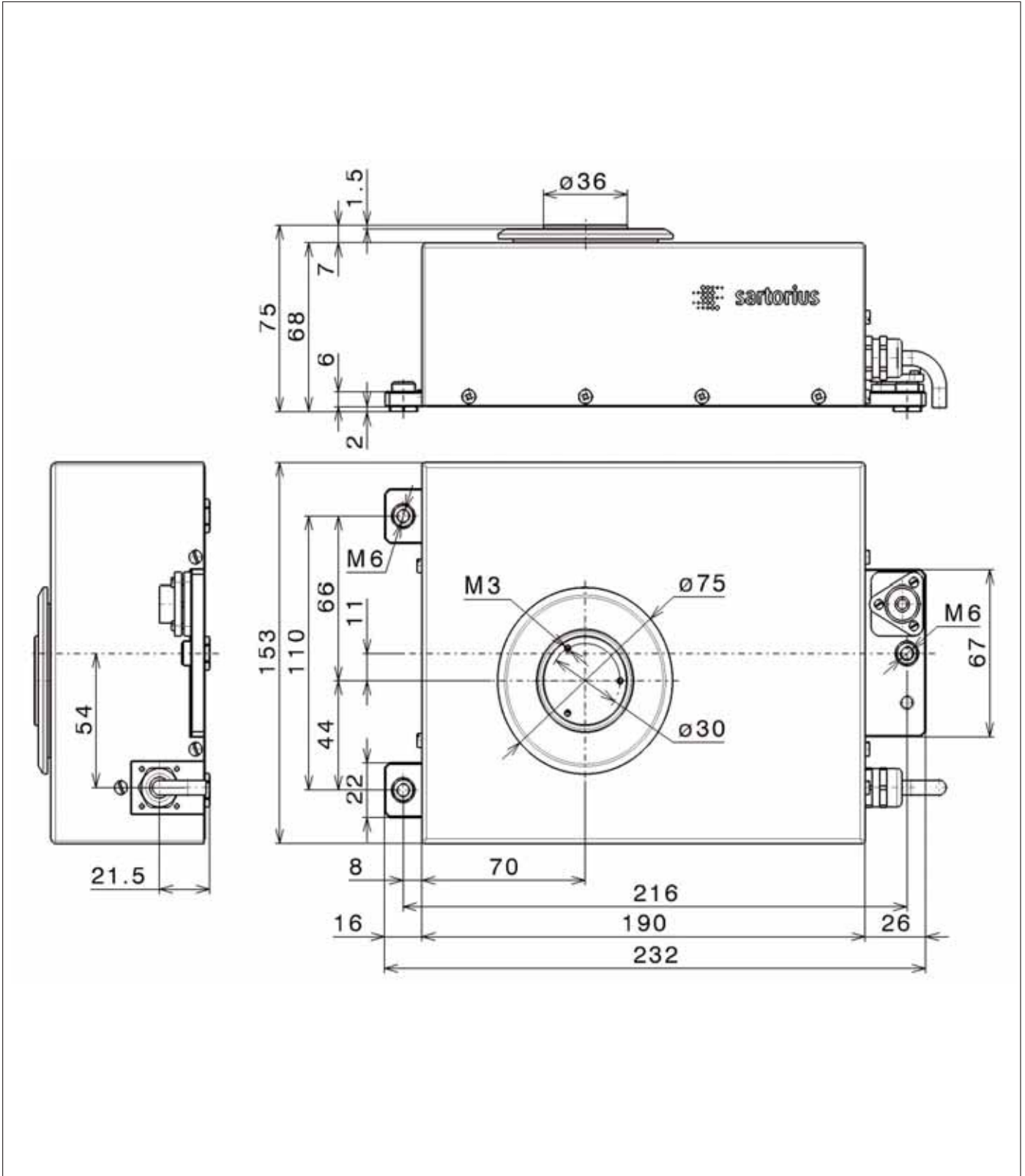

All dimensions are given in millimeters

Accessories/Options

Product	Order No.
Display and control unit with cable (0.5 m) for connection to electronics module	FF03-VF3659
Second display for connection to data interface	YRD02Z
Configuration software for settings, calibration/adjustment and setting the preload	YAD01IS
SartoConnect data transfer software (for loading weight values in a PC running Windows 95/98/NT and processing with application programs such as MS Excel, Access, etc.) incl. adapter cable (1.5 m) from weigh cell to PC (12-pin to 9-pin)	YSC011
Data cables:	
– for PC connection, 25-pin	7357312
– for PC connection, 9-pin	7357314
Evaporation trap for pipette calibration (adapter included)	YCP01WZA
Draft shield and 50-ml stainless steel vessel	YDS01WZA
Carrying case	YDB01WZA
Other data interfaces (for example, RS-485, etc.)	Available on request
AC adapter, IP40 protection in accordance with VDE* 0470/529	
– Europe:	6971966 + cable: 6900900
– US:	6971413
– UK:	6971966 + cable: 6971945
– Switzerland:	6971966 + cable: 6971979
– Denmark:	6971966 + cable: 6971980
– Australia:	6971966 + cable: 6900905
– South Africa:	6971966 + cable: 6900902
– India:	6971983 + cable: 6971964
Additional options and accessories available on request	

* VDE = Verband der Elektrotechnik, Elektronik, Informationstechnik
(Association for Electrical, Electronic & Information Technologies)



EG-Konformitätserklärung *EC Declaration of Conformity*

Sartorius AG
37070 Göttingen
Germany

erklärt, dass das Betriebsmittel
declares that the equipment

Gerät:
Apparatus: Elektronische Präzisionswaage
Electronic precision weighing instrument

Baureihe / *Batch:* WZA, WZA / GPC -CW

Typbezeichnung:
Type: Siehe Anhang 1
See Annex 1

mit den Regelungen der folgenden Europäischen Richtlinien übereinstimmt:
complies with the regulations of the following European Directives:

Richtlinie 2004/108/EG
Directive 2004/108/EC Elektromagnetische Verträglichkeit
Electromagnetic compatibility

Richtlinie 2006/95/EG
EC Directive 2006/95/EC Elektrische Betriebsmittel zur Verwendung innerhalb
bestimmter Spannungsgrenzen
Electrical equipment designed for use within certain voltage limits

Das Gerät erfüllt die anwendbaren Anforderungen der in Anhang 2 aufgeführten
harmonisierten Europäischen Normen.
*The apparatus meets the applicable requirements of the harmonized European Standards listed
in Annex 2.*

Sartorius Mechatronics
Göttingen, 2007-09-12



C. Oldendorf
Prokurist, Leitung
Technologie & Innovation
Sparte Mechatronik
*Vice President, R&D
Technological Operations & Innovations
Mechatronics Division*



Dr. D. Klausgrete
Leitung
International Certification Management
Sparte Mechatronik
*Head of
International Certification Management
Mechatronics Division*

Sartorius AG
Weender Landstrasse 94–108
37075 Goettingen, Germany

Phone +49.551.308.0
Fax +49.551.308.3289
www.sartorius.com

Copyright by Sartorius AG,
Goettingen, Germany.
All rights reserved. No part
of this publication may
be reprinted or translated in
any form or by any means
without the prior written
permission of Sartorius AG.
The status of the information,
specifications and illustrations
in this manual is indicated
by the date given below.
Sartorius AG reserves the
right to make changes to
the technology, features,
specifications and design of
the equipment without notice.

Status:
March 2008, Sartorius AG,
Goettingen, Germany