



The WZA-SE Series



OEM weigh cells

WZA25-NC

Outstanding features:

The WZA25-NC has a capacity of 20 g with a readability of 10 μ g combined with a small housing. A multiple weighing system can be arranged in linear fashion with a distance of 25 mm between the weighing pins. Head to Head configuration allow 12.5 mm track distance.

The weigh cell consist of two parts:

- A monolithic weighing system in stainless steel IP44 housing
 - Aluminium electronic box, all connection via the front
-
- Force compensation technology weighing system with a resolution of 0.01 mg
 - Internal calibration weight by external control for easy checks in automated environments
 - Excellent weighing technology bundled with easy adaptation
 - Adjustable load receptor with overload protection and lift-off protection
 - Possibility for under floor weighing
 - Interconnection on electronic front panel
 - LED's to control power and data transfer
 - Fast warm-up by separation of weighing system and electronics
 - RS232C interface for configuration and data transfer
-
- Optional PC-software with menu setting, weigh data display and internal calibration functions
 - Display can be plugged during operation
 - Several units can be combined by parallelization of multiple weigh cells – each every 25 mm.
 - Customer housing of multiple weigh cells can fitted easily over the weigh cells. Sealing rings on top can be dismantled and refitted after placement of customer housing.

Model WZA...	25-NC
Capacity	20 g
Readability	0.01 mg



WZA25-NC
Dimensions in mm

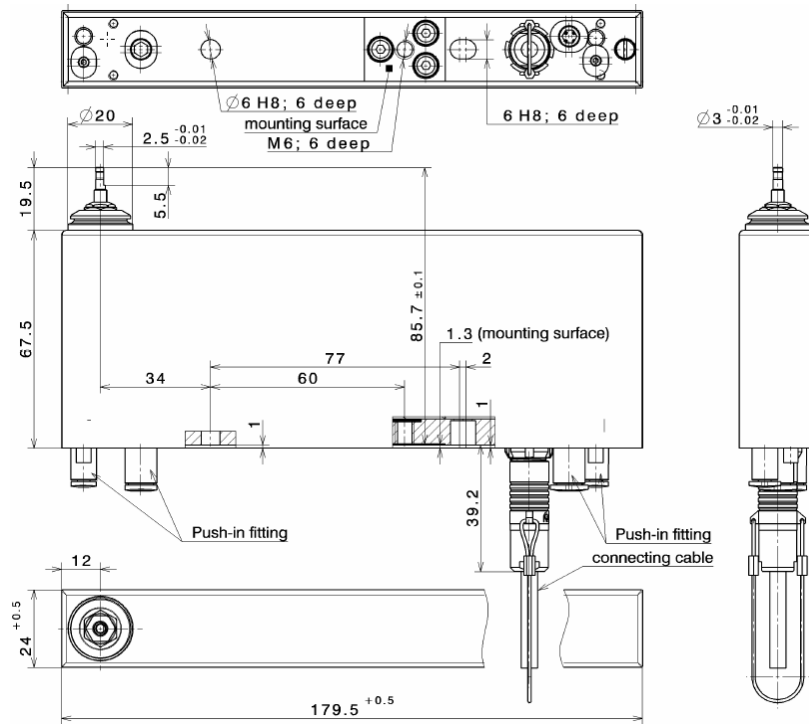

Technical Data

Model	WZA25-NC	
Capacity	20 g	
Readability	10 µg	
Preload min. ¹⁾	5 g	
Repeatability (standard deviation) ²⁾	≤± 20 µg	
Linearity	≤± 50 µg	
Measuring time ^{2) 3)}	0.8 s / ±10 µg 400 ms / ± 100 µg 250 ms / ± 1 mg	
Operating temperature range	+10 +30 °C	
Allowable temperature range	+5 +40 °C	
Weigh cell dimension	24 x 180 x 87 mm (base x height)	
Electronic dimension	130 x 208 x 45 mm (base x height)	
Pin for weighing pan / load receptor	3 mm Ø / 20 mm above housing, integrated overload and lift off protection	
Cable length weigh cell to electronics	3 m	
Power supply	TNG11-2 UNI / 6971993, 115/230 V _{AC} , +15 ... - 20%, 48-60 Hz	
Power supply (alternative)	12...26, optimal 15V (+15% -10%); 0.5V _{PP} (Peak to Peak)	
Power consumption	8 VA (average)	
Interface	RS232C , software / hardware handshake; No system power via RS232 connector	
Materials	Housing	Stainless steel 1.4404 / AISI316L
	Weighing pin	Titanium
	Electronic Box	Transparently passivated aluminum
IP rating related to DIN EN 60529	IP44	

Options / Accessories

Windows configuration software for test and adjustment	Sartorius CAS Suite
--	---------------------

Liquid-crystal display	YAC01ED
------------------------	---------

Sartorius Weighing Technology GmbH
Weender Landstrasse 94-108
37075 Goettingen, Germany

Phone +49.551.308.0
Fax : +49.551.308.3502

info.mechatronics@sartorius.com
www.sartorius-mechatronics.com

- 1) the preload can be configured by using the Sartorius CAS Suite H8S software; higher preload will reduce the weighing range
- 2) depending on measurement equipment set-up and conditions;
- 3) measuring time is the time in which the measured value is in the given range around the static end value; test weight is approx. 25% of the weighing range.

Specifications are subject to change with

Current status: July 2011
Version: 2.0